	Flame Arrester 933-S400.01/6x0,5-d/D4IIAP2T1 Instructions for Operating and Maintenance	REV 1.0
		Page 1/7

This Instruction for Operating and Maintenance is applicable for the following flame arrester model:

Table Type description

Nominal width	Type	EC-Type Examination Certificate Number
DN400 / 16"	933-S400.01/6x0,5-d/D4IIAP2T1	IBExU14ATEX2011 X

The data sheet with dimensions and the pressure drop/volume flow rate diagram are available.

1. Use

The said model of the series 01 with flange joint of nominal width DN400 meets the requirements of the European Guideline 2014/34/EU and the harmonised standard for flame arresters EN ISO 16852:2016 as autonomous protection system for intended use in potentially explosive atmospheres.

Its general suitability as an **in-line stable detonation flame arrester** for use in inflammable gas/air mixtures and vapour/air mixtures of inflammable liquids of explosion group IIA (standard gap width > 0,90 mm) was proved in a test at the Institut für Sicherheitstechnik GmbH IBExU Freiberg as EUROPEAN NOTIFIED BODY no. 0637 according to Article 9 of the Guideline 2014/34/EU. Always use it within the purview of the entire safety concept of the corresponding system and combine additional explosion safety measures, if required.

For preventing a flame transmission, these detonation arresters in the pipes can be used in atmospheric conditions [pressure: 0,8 bar (absolute) to 1,1 bar (absolute), temperature: -20°C to +60°C] for protection against stable detonations, deflagrations and short time burning at the flame arresters for explosive vapour/gas-air mixtures of the explosion group IIA.

Furthermore, the limit values according to Table 1 for the maximum permissible operating pressure p_0 considering the maximum permissible operating temperature T_0 must be adhered to:

Table 1: Limits for the operating status

Nominal width	p_0 MPa (absolute)	T_0 °C
DN400 / 16"	0,12	60

The flame arrester can be equipped in the case of stabilized burning on the flame arrester element with one or more integrated temperature sensors (resistance thermometers) on both the sides.

A stabilized burning on the flame arrester element must be stopped by installing an integrated temperature sensor (resistance thermometer) at the unprotected side of the flame arrester in connection with an automatic triggering of emergency functions (interruption or inertisation of the mixture flow) when the operation temperature of ≥ 20 K is exceeded.

The maximum permissible burning duration t_{BT} for short time burning at the flame arrester is 1 min.

With the delivery of the flame arrester, the technical parameters are documented along with the EC-Type Examination Certificate Number in the factory test certificate.

In the declaration of compliance, the adherence to the Essential Health and Safety Requirements is confirmed in accordance with the standards EN ISO 16852:2016 and EN 1127-1:2011.

Created By:	RMG	Date: 01.01.14	BS&B FlameSAF Limited, Limerick, Ireland
Approved By:	D. Hennessy	Date: 01.01.14	

	Flame Arrester 933-S400.01/6x0,5-d/D4IIAP2T1 Instructions for Operating and Maintenance	REV 1.0
		Page 2/7

2. Construction

The flame arrester comprises two covers (1) and (2), between the flame arrester element (3) is clamped, there are O-ring seals (4) for external sealing and connecting elements threaded bolt (5) and hexagonal nut (6) with protection cap (7).

The flame arrester's (3) grid cage (8) has six metal foil elements (9), (10) and (11) with varying winding direction: (9)- turned straight, (10)- turned right, (11)-turned left.

The metal foil elements are made of one crimped and one flat ribbon of 10 mm width and 0,15 mm thickness. The ribbons are rolled along each other in compact layers and build a triangular channel in the centre with a maximum height of 0,5 mm.

The metal foil elements are kept apart with distance star (12) and are fastened axially with the stars (13) and (30) using the screw (14). The screw (14) is secured against loosening with the help of safety washer (15) and adhesive on the thread.

Using two lifting eyes (17), lifted through threaded bolts (5), the flame arrester element (3) is positioned between the covers (1) and (2).

On the inner sides of the cover flanges some threaded bolts have additional nuts (6) and washers (18) which enable an axial constricting for dismantling the flame arrester element (3).

Two threaded holes on the cover (1) are sealed with screw plug (19) and accompanying sealing ring (20). The screw plug on the bottom serves as condensation outlet; the screw plug on the upper flange is replaced on site along with the sealing by a resistance thermometer (21).

In case of use of resistance thermometer, two covers (1) are used on both the sides of the flame arrester.

On customer's demand there will be threaded holes M10x1 for pressure measuring on the inlet and outlet flange which are closed by screw plug (22) and sealing ring (23).

3. Marking

Information with which the flame arrester system is identified is mentioned on the type label (Item 25) and warning sign (Item 26). The following details are provided:

TYPE LABEL

- name and address of the manufacturer
- type identification according to "Table Type description"
- number of the certificate (EC-Type Examination Certificate Number) according to "Table Type description"
- factory number with year of manufacture
- the international standard for flame arresters: "ISO 16852"
- the special mark for prevention of explosions and alphabet 'G' (for areas that have explosive gas, vapour, air-mixtures)
- explosion group IIA
- CE mark with number of the indicated inspection office for production monitoring phase: „0589“

WARNING SIGN

- the word "Warning" with the note "Flame arresters have installation and application limits. Type design in accordance with ISO 16852"
- the mark "DET 4" means: tested for stable detonation without restriction
- the mark 'BC' for stabilized burning plus the classification 'b' for short time burn or 'c' for no burn time; if 'b' has been specified, then there will be an additional mention of the burning duration $t_{BT} = 1 \text{ min}$
- the explosion group IIA

Created By:	RMG	Date: 01.01.14	BS&B FlameSAF Limited, Limerick, Ireland
Approved By:	D. Hennessy	Date: 01.01.14	

	Flame Arrester 933-S400.01/6x0,5-d/D4IIAP2T1 Instructions for Operating and Maintenance	REV 1.0
		Page 3/7

- the maximum operating temperature $T_0 = 60^{\circ}\text{C}$
- the maximum operating pressure $p_0 = 0,12 \text{ MPa}$

The flame arrester has an easily visible stamp on the grid cage (8): "BS&B-6x0,5-d"

The metal foil element is labelled on the external ribbon as:

- short name of the manufacturer
- gap width
- material number
- direction of winding

Example: "BS&B-0,5-1.4571-R"

The parts tested for leak proofness and strength are indicated through a stamp.

The saved side is marked by a red sticker.

Option: If the flame arrester has a resistance thermometer, the cover (1) has an adhesive label (27) with warning notice for short time burning.

4. Installation

The positioning and installation of the flame arrester in the plant must take place under the purview of the directives applicable at the place of use; it is particularly imperative to follow the accident prevention directives of the area of installation.

The flange covers must be removed before installing in the pipeline.

The criteria mentioned in the EC-Type Examination Certificate under Point [17] - Special conditions for safe use - related to the installation must be adhered to. It is especially important to check the use of resistance thermometer for signalling stabilized burning at the flame arrester.

The following assembly instructions must be observed:

- The flame arrester must be installed only on those pipelines, whose pipe diameter
 - on the unprotected side shall be no greater than the flame arrester connection
 - on the protected side shall be no less than the pipe diameter on the unprotected side
- If a continuous burning at the flame arrester cannot be ruled out, at least one resistance thermometer must be installed at the source of ignition side. The mark (red point) on the cover (2) indicates the connection side to be connected with the system component to be protected against flame transmission. If continuous burning is expected on both sides of the flame arrester, one temperature sensor must be installed at both sides.

The flame arresters are fundamentally equipped with connecting flanges according to ISO 7005-1 (steel flanges) in the pressure level PN10, PN16 or PN20. The pressure level PN20 is compatible with the American flange class 150 RF according to ANSI B16.5. If required, the flange connections can also be delivered in accordance with the Japanese industrial standard JIS B 2220.

Flat seals with sealing rated value of $k_0K_D \leq 25b_D$ are recommended for the flange connections. While installing flanges, it must be ensured that the seal faces are not damaged and there are no foreign bodies or dust between the flanges so that there are no gaps. The system should be checked thoroughly for proper sealing before commissioning it. The test pressures of the flame arrester specified in the test certificate must not be exceeded.

Vertical as well as horizontal installation on the system is permissible.

The flame arrester must not be a bed for the pipe and should be installed with low-stress.

Created By:	RMG	Date: 01.01.14	BS&B FlameSAF Limited, Limerick, Ireland
Approved By:	D. Hennessy	Date: 01.01.14	

	Flame Arrester 933-S400.01/6x0,5-d/D4IIAP2T1 Instructions for Operating and Maintenance	REV 1.0
		Page 4/7

For dismantling of the flame arrester element (3) and the resistance thermometer (21) assembly clearance is necessary with at least the measurements given in Table 2 (see Spare part drawing).

Table 2: Dismantling dimensions D and E and weight of the stainless steel flame arrester element (3)

DN		400
D	mm	810
E	mm	1320
Weight	kg	221

The assembly of the resistance thermometer delivered separately from the flame arrester must take place by replacing the screw plug in the corresponding threaded hole of the cover flange with corresponding sealing. The screwing must be secured against accidental loosening in the thread with adhesive "Loctite 221".

The assembly guidelines of the resistance thermometer's manufacturer and the conditions for ensuring the conformity must be adhered to while connecting the temperature sensor to the measurement system. The switching between resistance thermometer and the device for stopping mixture flow or a similar measure (triggering emergency function) must take place in such a way that within 30 sec after the identification of the flame by the resistance thermometer, the risk status is recognised.

5. Maintenance

The maintenance includes a periodic visual inspection of the flame arrester, in particular the metal foil elements, with respect to contamination and consistency and a periodic functions check of the resistance thermometer. The time intervals for maintenance works depend on the operating conditions and contaminating level of the individual media and must be decided by the operator.

For cleaning works the flame arrester element has to be taken out of the plant. Therefore, the weights according to Table 2 shall be taken into consideration. Check the status of the sealing (4) after the disassembly.

In case of negligible contamination the flame arrester element (3) shall be blown up with compressed air or hot steam against the operating flow.

If the contamination level is high or there are sticky impurity to the surface of the metal foil element, rinsing with a cleaning agent may also be considered. However, all parts covered in the cleaning agent must then been blown dry.

Ensure that no mechanical modifications are made to the metal foil elements and housing parts of the flame arrester during the cleaning works. Check that screw (14) is secured and fastened properly (Table 3).

Table 3: Fastening torque of the screw (14)

DN		400
Torque	Nm	600

Explosions along with stabilized burning at the flame arrester element lead to considerable mechanical and thermal stress. If changes in the foil element structure are visible during a fire on the flame arrester element or the coils have unwound, the flame arrester element must be replaced.

Created By:	RMG	Date: 01.01.14	BS&B FlameSAF Limited, Limerick, Ireland
Approved By:	D. Hennessy	Date: 01.01.14	

The flame arrester element must be replaced by a new one if

- there was a fire on the flame arrester element
- slackening or slipping in the structure of the metal foil elements is visible
- there are visible damages on the metal foil elements from corrosion
- a visible residual contamination of more than 30% of the free flow area has remained despite cleaning a very dirty metal foil element

All works in connection with the cleaning and replacement of flame arrester element shall be executed only by trained and authorized skilled personnel.

Check the functionality of the resistance thermometer after a fire on the flame arrester.

While replacing the sealing (4), ensure that they are lightly lubricated with conventional silicon grease (order no. 00 027 079); they must be protected from damage during the assembly.

The threaded bolts (5) should be also lightly greased with silicon grease around the threads and fastened with the torque specified in Table 4.

Table 4: Fastening torque of the screw joint (5), (6)

DN	400
Torque Nm	300

Attention: For “silicone and grease free flame arresters” all seals, screws and nuts should be assembled without using silicone or grease.

Check the external sealing of all pressurised flange and threaded joints.

It is recommended to keep one suitable spare flame arrester element (3) for every flame arrester in use.

While replacing components, use only the -original-spare parts listed in the Spare parts list to ensure safety.

6. Spare parts list

Table 5: Spare parts DN400

Item No.	Designation	No.	Material	Order-No.
				DN400
3*	Flame arr. element 6x0.5-d Flame arr. element 6x0.5-d-N Flame arr. element 6x0.5-d-VF Flame arr. element 6x0.5-d-VF Flame arr. element 6x0.5-d-VF Flame arr. element 6x0.5-d-VF	1	NSt NSt NSt H-C4 H-C22 H-C246	FET15543140 FET15543140N FET15543140VF FET15543142VF FET15543144VF FET15543146VF
4*	O-ring	2	NBR FPM FEP	780018100 780018200 780018300
5	Threaded bolt	14	St NSt	232087023 232087123
6	Hexagonal nut	36	St NSt	200000239 201542823
7	Protection cap	28	K	702049700
18	Washer	8	St NSt	052098300 940131000
19	Screw plug	2	St NSt H-C4 H-C22 H-C276	215031200 212097500 432043500 232043500 232072400
20*	Sealing	2	LM PTFE	504650200 532036000
21*	Ex(i) -thermometer 3-wire system 4-wire system 3-wire system + transmitter	1	NSt	662037420 662068823 662071923
22	Screw plug	2	St NSt H-C4 H-C22 H-C276	215130500 212025100 432042700 232042700 232073200
23*	Sealing	2	LM PTFE	504580700 532037700

Note: Parts marked with * shall be available for maintenance works.

Material marks

St ... steel	LM ... light metal	FPM ... Viton
NSt ... stainless steel	K ... plastic	NBR ... Perbunan (N)
H-C4 ... Hastelloy C4	H-C22 ... Hastelloy C22	H-C276 ... Hastelloy C276
FEP ... Fluoro-plastic (VF)	PTFE ... Fluoro-plastic	



Flame Arrester
933-S400.01/6x0,5-d/D4IIAP2T1
Instructions for Operating and Maintenance

REV 1.0

Page 7/7

Spare part drawing DN400

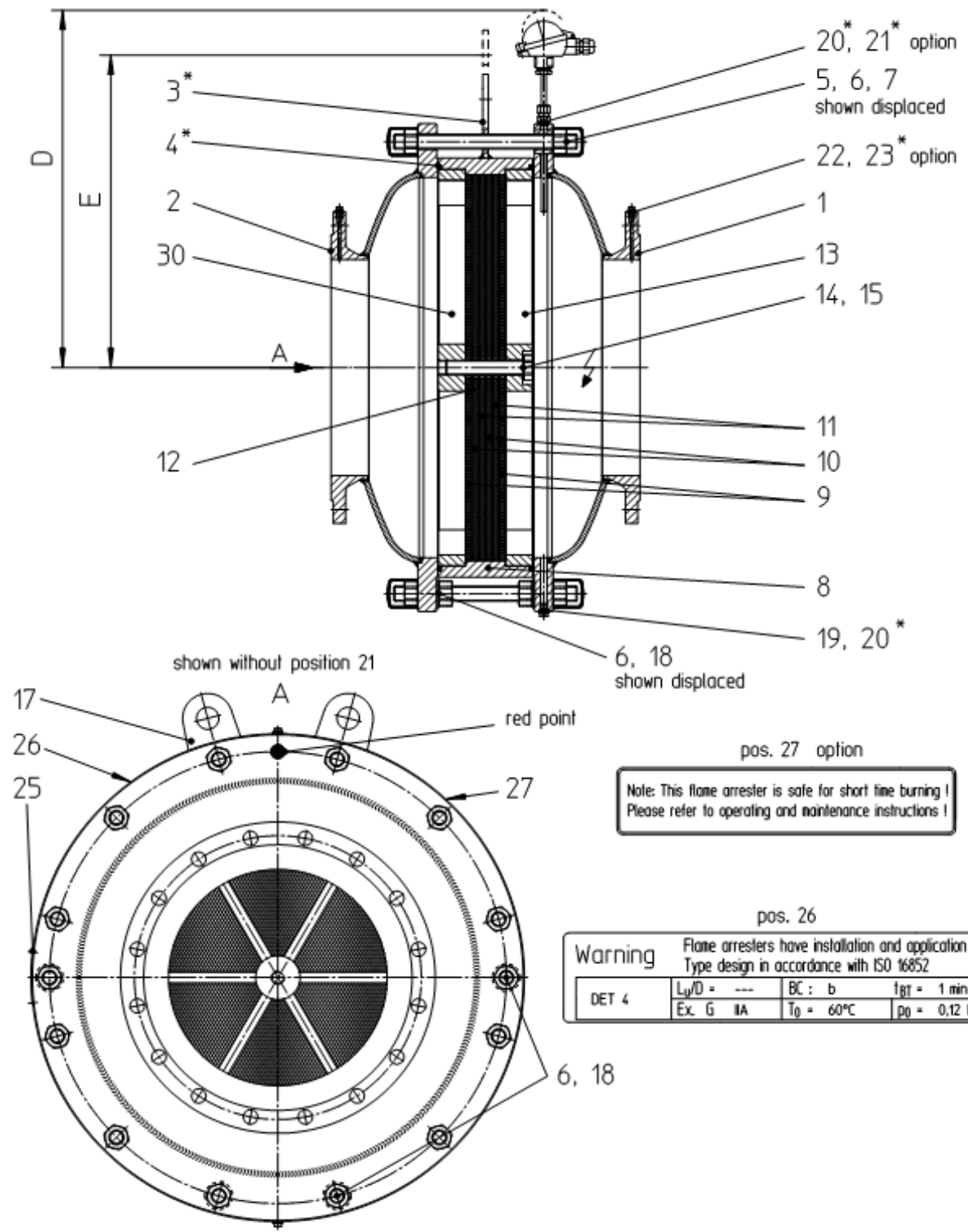

Note: Parts marked with * shall be available for maintenance works.
 Dimension D and E are dismantling dimensions.

Created By:	RMG	Date:	01.01.14	BS&B FlameSAF Limited, Limerick, Ireland
Approved By:	D. Hennessy	Date:	01.01.14	