	Pressure and Vacuum Vent 943-VM – 300 Instructions for Operation and Maintenance	REV 2
		Page 1/6

This Instruction for Operation and Maintenance is applicable for the following vent models:

Table 1: Type description

Size	Type	EU-Type Examination Certificate Number
DN300 / 12"	943-VM 300	IBExU17ATEX1106 X

Dimension sheets and Pressure drop/volume flow charts may be provided under request.

1. Use

The Pressure and Vacuum Vent 943-VM complies with the following standards:

EN ISO 80079-36:2016	Non-electrical equipment for potentially explosive atmospheres Basics methods and requirements
EN ISO 80079-37:2016	Non-electrical equipment for explosive atmospheres – Non-electrical type of protection constructional safety "c", control of ignition sources "b", liquid immersion "k"

The general suitability as pressure and vacuum vent for device group II, category 1/2 when used with inflammable gas/air mixtures and vapour/air mixtures of inflammable liquids of explosion group IIB (MESG \geq 0.5 mm) have been verified by tests executed at the Institute for Safety Technology IBExU GmbH Freiberg and the results were confirmed by the issued EU-type examination certificate **IBExU17ATEX1106 X**.

The following valve insert/pallet settings are applicable:

- Set-pressure for vacuum: 2.5 up to 70 mbar *) *) factory pre-set default
- Operating temperature: surface temperature \leq 80% of ignition temperature medium (please attend data sheet)

As part of the documentation package, the product is delivered with a factory Test Certificate according to EN 10204, which includes the technical features of the product as well as the EU-type examination certificate number. Also, as part of the documentation package, a Declaration of Conformity is issued, assuring compliance with standards EN ISO 80079-36 / 37:2016, as well as compliance with the ATEX directive 2014/34/EU.

2. Construction

The vent consists of a cast iron/stainless/carbon steel housing (item 1), equipped with a vacuum pallet (10). The housing is sealed with two covers (3 & 7) that are mounted to the housing by screws and O-ring seals (8 & 9). The valve pallet is guided by a guiding bush (4), that is mounted to the seat side cover.

For protection against the weather effects, the seat side of the vent is equipped with a protective screen (6) and this protective screen is secured in place with bolts and washers.

The valve pallet is pre-set for the customer's specific set-up pressure via weight discs. The valve pallet may be provided with FEP seal.

The materials used in the components of the vent have to be adequate to the operation and process media conditions so that the overpressure protection provided by the vent can be assured.

The product may be fitted with custom pallet configurations depending on the order request, the most common types are the standard design, which has a lip and flat pallet design, which has no lip, please refer to Figure 1 for better understanding and visualization.

The pallet type shall be properly identified for ordering spare parts.

Created By:	D. Hennessy	Date: 03/07/17	BS&B FlameSaf Limited, Limerick, Ireland
Approved By:	V. O'Hara	Date: 03/07/17	

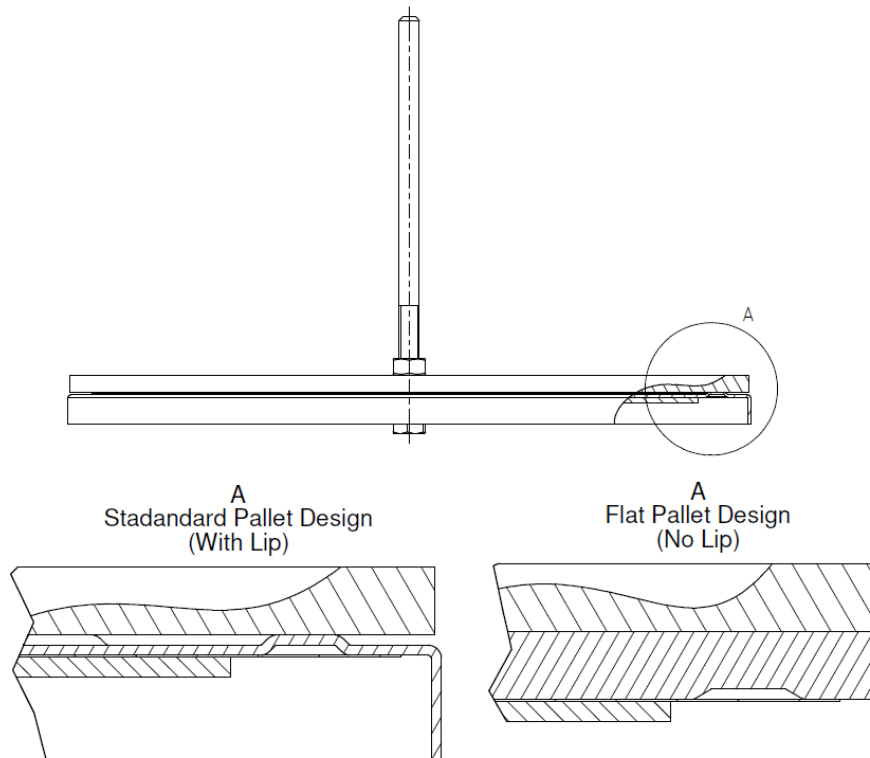

Figure 1 – Pallet Design

3. Marking

The product is supplied with a nameplate (please refer to the last page) that provides important information to the customer about the product and its limitations. Below are some of the information provided:

Nameplate:

- Name and address of the Manufacturer
- Product Type (including element configuration)
- Serial Number and year of manufacture
- EU-type examination certificate number
- EN number
- EX mark, followed by the device group information II, category 1/2 and the letter “G” (for classified areas where explosive gases, vapors and/or air mixtures are present)
- CE mark, followed by the Notified Body number (2460)
- Set Pressure setting for positive pressure and vacuum
- Flow values at opening pressure

Created By:	D. Hennessy	Date: 03/07/17	BS&B FlameSaf Limited, Limerick, Ireland
Approved By:	V. O’Hara	Date: 03/07/17	



4. Installation

The arrangement and the installation of the vent on the equipment shall be done under observance of the rules applicable to the relevant range of use. Accident prevention measures and risk assessment to take place before installation.

Health and safety guidelines to be followed. The installation of the valve on the equipment shall be done at the correct orientation (vertical).

The vent may be provided with flange connections that can be of bolting configuration as per EN 1092, ASME/ANSI B16.5, JIS B 2220 and other configuration under special request.

For the flanged connections, flat gaskets with a sealing parameter $k_{oD} \leq 25b_D$ are recommended. When assembling flanges, make sure the sealing surfaces are not damaged and free from any foreign material to avoid any leak paths. The system may be checked against leakages before commissioning. The test pressures of the vent must not be exceeded.

The pipeline down and upstream the vent must be properly supported so that the vent doesn't bear any piping stress.

The vent has to be included in the equipotential bonding of the vessel or plant.

Process gases and vapours are to be free of particles and are not to be exothermic in nature.

To prevent transportation damage, the valve pallet is shipped separate from the vent and need to be assembled in the valve before operation.

The pallet is individually packed and marked with the valve serial number.

Pallets shall be installed as per the following steps:

- Remove the seat side cover (3) by loosening the cap screws
- Install the Pallet carefully on top of the Vacuum seat (2)
- Replace the cover (3) making sure that the guiding rod of the pallet is properly inserted and guided inside the guiding bush (4)
- Tighten the cover screws

5. Maintenance

The maintenance includes a periodic visual inspection of the vent with regards to contamination and appearance. The intervals for the maintenance works depend on the operating conditions and how contaminating the process media is. The interval of maintenance has to be defined by the end user.

In case of major contamination, a flushing with a cleaning agent can be carried out. After cleaning, all parts shall be blown dry. During the cleaning works, no mechanical modifications may be done to any internal parts of the vent or to the housing. The device must not be modified in any way.

All works in connection with repair and replacement of components shall be executed only by trained and authorized, skilled personnel.

Valve seat and valve pallet shall be checked for contamination, damages and examined in particular for integrity as well. Damages or imperfection on valve seats surfaces must be repaired by professional grinding or lapping equipment. The main seal (FEP or other material) shall not present any signs of damage or imperfections. If any damages are present the parts must be replaced by new ones.

Opening and re-installation shall be performed according to instructions of Section 4.

It is recommended to keep a spare parts kit for each seal on hand at all times. In case of replacement of parts, only genuine parts, supplied by BS&B FlameSaf Ltd, may be used for any maintenance/repair work. Please refer to the Spare Parts List for the part numbers to be used to re-order parts.

Created By:	D. Hennessy	Date: 03/07/17	BS&B FlameSaf Limited, Limerick, Ireland
Approved By:	V. O'Hara	Date: 03/07/17	



**Pressure and Vacuum Vent
943-VM – 300
Instructions for Operation and Maintenance**

REV 2

Page 4/6

6. Spare parts list

Table 2: Spare Parts List Table

Item No.	Description	Qty	Material	Part Number (DN300)
2*	Seat	1	SS	999967740
3	Cover (Seat Side)	1	SS	999967750
4	Guiding Bush	1	SS	182055000
5	Guiding Bush Lock Washer	1	SS	202085200
6	Protective Mesh	1	SS	999967790
7	Cover (Process Side)	1	SS	999967770
8*	O-ring Cover (Seat Side)	1	NBR	792038008
			FPM	792038004
			EPDM	792038009
			PTFE Encapsulated	792038002
9*	O-ring Cover (Process Side)	1	NBR	792038006
			FPM	792038003
			EPDM	792038007
			PTFE Encapsulated	792038001
10*	Valve Pallet Assy - Standard Design **	1	SS / FEP	FET15419172
	Valve Pallet Assy - Flat Design **	1	Aluminium / FEP	FET15419175

Notes:

- * Essential parts for periodic preventive maintenance
- ** Valve Pallets supplied without calibration weights
- CS = Carbon Steel
- SS = Stainless Steel

Created By:	D. Hennessy	Date: 03/07/17	BS&B FlameSaf Limited, Limerick, Ireland
Approved By:	V. O'Hara	Date: 03/07/17	



943-VM 300 - Spare Parts Drawing:

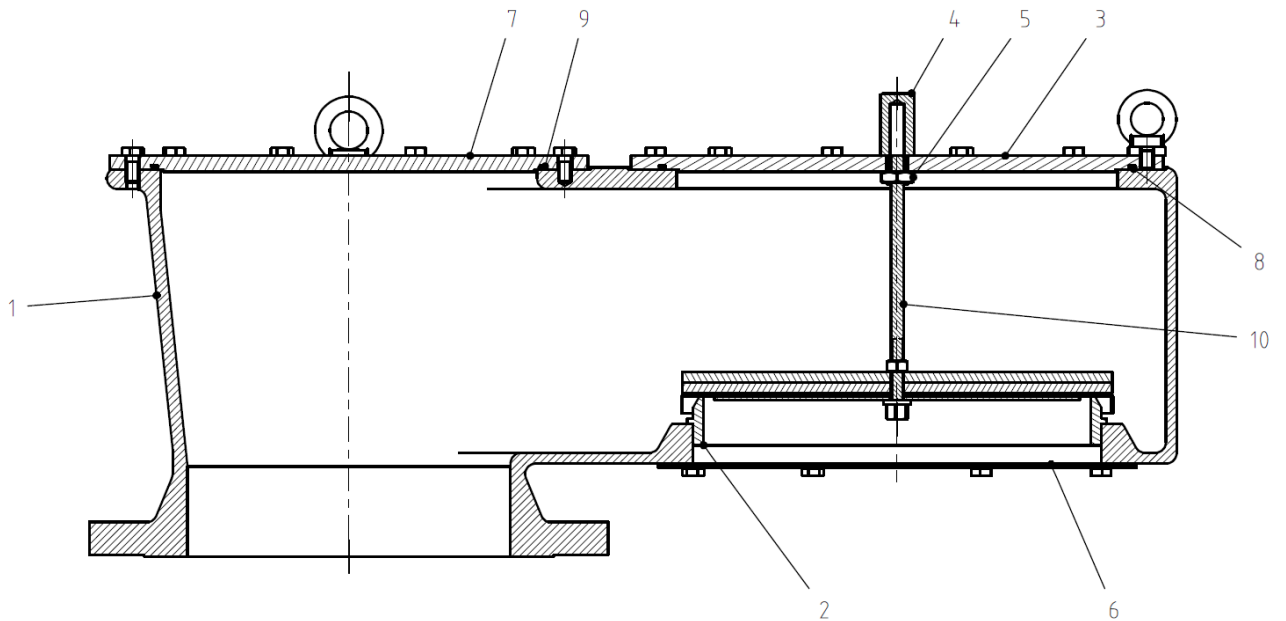

BS&B FlameSaf			
Raheen Business Park, Limerick, Ireland.			
Type	<input type="text"/>		
Cert. No.	<input type="text"/>		
Ser. No.	<input type="text"/>	DN <input type="text"/>	
Set Pressure	Opening Pressure	Volume Flow Rate *	
Vacuum	<input type="text"/>	mbar	<input type="text"/>
Pressure	<input type="text"/>	mbar	<input type="text"/>
* Air in standard conditions at opening pressure			

Figure 2 – Spare part's Drawing

Created By:	D. Hennessy	Date: 03/07/17	BS&B FlameSaf Limited, Limerick, Ireland
Approved By:	V. O'Hara	Date: 03/07/17	