	Flame Arrester 934-B-E 80(65)/2x0.3/IICP1T1.1 Instructions for Operation and Maintenance	REV 0
		Page 1/7

This Instruction for Operation and Maintenance is applicable for the following flame arrester model:

Table 1: Type description

Size	Type	EU-Type Examination Certificate Number
DN65 / 2 ½"	934-B-E 65/2x0.3/IICP1T1.1	IBExU18ATEX2113 X
DN80 / 3"	934-B-E 80/2x0.3/IICP1T1.1	

The data sheet with dimensions and the pressure drop/volume flow rate diagram are available.

1. Use

The flame arrester types listed in this document meet the requirements of the European Guideline 2014/34/EU and the harmonised standard for flame arresters EN ISO 16852:2016 as autonomous protection system for intended use in potentially explosive atmospheres.

Its general suitability as **End-of-line Deflagration Flame Arrester** for use with inflammable gas/air mixture and vapour/air mixture of inflammable liquids of the explosion group IIC (MESG < 0.50 mm) has been verified by tests performed at the Institut für Sicherheitstechnik GmbH IBExU Freiberg, EUROPEAN NOTIFIED BODY no. 0637 according to Article 9 of the Guideline 2014/34/EU. Always use it within the purview of the entire safety concept of the corresponding system and combine additional explosion safety measures, if required.

For preventing a flame transmission, these deflagration arresters can be used at atmospheric conditions [pressure: 0,8 bar (absolute) to 1,1 bar (absolute), temperature: -20°C to +70°C] for protection against deflagrations at the flame arrester for explosive vapour/gas-air mixtures of the explosion group IIC.

Furthermore, the limit values listed in Table 1 are the maximum permissible operating pressure (p_0) and maximum permissible operating temperature (T_0), customer shall never operate beyond these limits:

Table 2: Limits for Operation

Size	p_0 MPa (absolute)	T_0 °C
DN65 / 2 ½"	0.11	70
DN80 / 3"		

As part of the documentation package, the product is delivered with a factory Test Certificate according to EN 10204, which includes the technical features of the product as well as the EU-Type Examination Certificate number.

Also, as part of the documentation package, a Declaration of Conformity is issued, assuring compliance with standards EN ISO 16852 and EN 1127-1, as well as compliance with the ATEX directive 2014/34/EU.

Created By:	T. Freitas	Date: 08/02/22	BS&B FlameSaf Limited, Limerick, Ireland
Approved By:	B. Murphy	Date: 08/02/22	



Flame Arrester
934-B-E 80(65)/2x0.3/IICP1T1.1
Instructions for Operation and Maintenance

REV 0

Page 3/7

4. Installation

The pipeline arrangement is defined by the customer, observing guidelines of relevant and applicable standards and the installation of the Flame Arrester shall be conducted by the customer following this IOM and the applicable standards. The customer shall observe the requirements and limitations of use outlined on relevant standards. The Flame Arrester shall be installed in the Vertical-up orientation.

Customer shall maintain a safe clearance between the Flame Arrester and any other object/obstacle that may obstruct the unit venting area and may affect its flow capacity/performance. Customer shall evaluate operating conditions and establish a safe clearance distance.

Before installation, customer must make sure the sealing surfaces are in perfect condition and free from any foreign objects, oil, or grease. Appropriate gaskets and torque shall be applied for a proper and leak tight installation.

For units with threaded process connections an appropriate sealing method must be used, according to the type of threaded connection chosen by the customer. Some types of thread may require the use of additional sealant, please follow the technical recommendations for the threads in use.

5. Maintenance

The Flame Arrester shall be periodically maintained, and the periodic maintenance includes a periodic visual inspection of the Flame Arrester, especially for the Arrester Elements. The Arrester Elements shall be inspected against deformation and contamination/blockage by any foreign bodies and/or process particles that may affect the gap width size. The time intervals for maintenance/inspection works depend on the operating conditions and contamination level of the process media. The maintenance/inspection frequency must be established by the user/customer.

To inspect the Arrester Elements, the Element Bank assembly (3) shall be dismantled from the Housing (1) by removing the Weatherhood Cap Screws (7), removing the Spacer Sleeves (5) and pulling up the Element Bank assembly (3).

Note: The Element Bank assembly (3) shall never be dismantled or have its Arrester Elements removed from the Element Bank Cage.

After removing the Element Bank assembly, the Arrester Elements shall be checked against corrosion, contamination and blockage.

During the periodic inspections, if light contamination is found, the Arrester Elements can be cleaned by blowing compressed air or hot steam in the opposite direction of the normal flow direction of the Arrester Element.

If the contamination level is high or there are impurities stuck to the surface of the Arrester Elements, the customer/user may also try to use a liquid cleaning agent/detergent by rinsing. The cleaning agent/detergent must be suitable for the materials of the Flame Arrester and may not corrode or damage the Flame Arrester parts in anyway. After rinsing, all parts shall be blown dry with clean compressed air.

The Element Bank must be replaced if even after cleaning its flow area still presents contamination/blockage of 30% or more of its flow area.

The Flame Arrester shall be replaced if any of the situations below occur:

- If any fire occurs at the Flame Arrester Elements
- If the Housing (1), Element Bank (3) or the Weatherhood (6) show damages
- If even after cleaning the Arrester Elements still have 30% or more of the flow area contaminated/blocked
- If corrosion is detected at the Arrester Elements

Created By:	T. Freitas	Date: 08/02/22	BS&B FlameSaf Limited, Limerick, Ireland
Approved By:	B. Murphy	Date: 08/02/22	



Flame Arrester
934-B-E 80(65)/2x0.3/IICP1T1.1
Instructions for Operation and Maintenance

REV 0

Page 4/7

The torque on the Element Bank (3) nut and bolt shall be checked at every periodic inspection and rectified as appropriate.

During the maintenance works no mechanical modification may be done to any parts of the Flame Arrester without BS&B FlameSaf Ltd written approval.

All maintenance works on the Flame Arrester shall only be performed by qualified and trained personnel.

It is recommended to always keep one spare Element Bank (3) in stock for each Flame Arrester in operation.

After finishing maintenance works the Flame Arrester must be checked against leaks.

Only genuine parts, supplied by BS&B FlameSaf Ltd, may be used for any maintenance/repair work performed on the Flame Arrester. Please refer to Table 3 (Spare Parts List) for the part numbers to be used to re-order parts.

6. Spare Parts List

Item No	Designation	Qty Needed / Flame Arrester	Material	Order Number	
				DN65 (2 ½")	DN80 (3")
3 *	Element Bank Assy	1	SS	FET15334235	FET15334235
5	Spacer Sleeve	1	SS	182007700	182007700
6	Weatherhood	1	SS	532099700	532099700

Table 3: Spare parts List

Notes:

- * Essential parts for periodic preventive maintenance
- CS = Carbon Steel
- SS = Stainless Steel

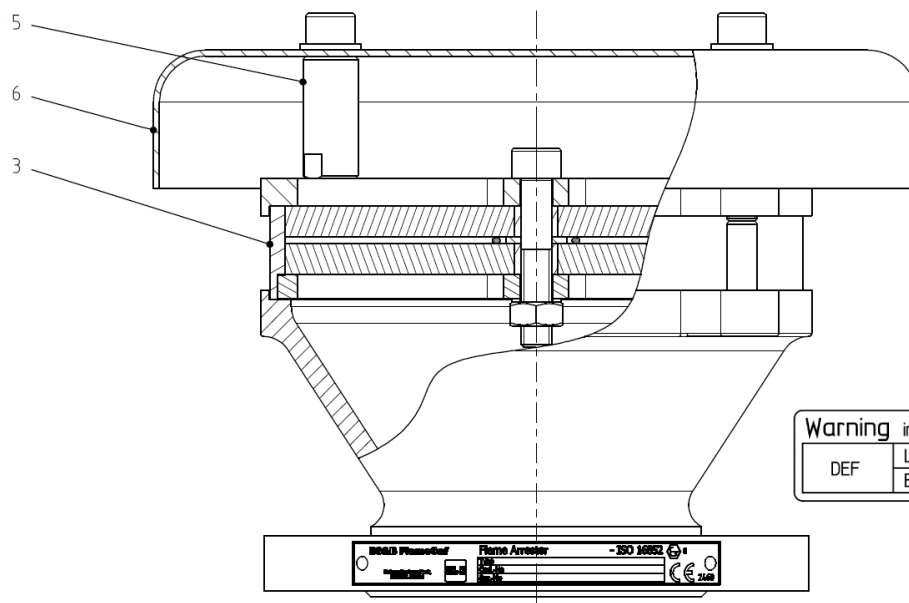

Warning installation and application limits in accordance with ISO 16852			
DEF	L _u /D = ---	BC :	i _{BT} =
	Ex. G	T ₀ =	P ₀ =

Figure 1 – Identification of parts and Warning Label / Hazard Sign

Created By:	T. Freitas	Date: 08/02/22	BS&B FlameSaf Limited, Limerick, Ireland
Approved By:	B. Murphy	Date: 08/02/22	