



Flame Arrester
934-B-E 125/1x0,3 to 934-B-E 300/1x0,3
Instructions for Operation and Maintenance

REV 1.0

Page 1/4

For the flame arrester type 934-B-E /1x0,3 catalogue data sheets as “Dimension sheet”, “Technical data” and “Pressure drop/volume flow charts” are available including the technical data, constructions and dimensions.

1. Use

The flame arrester type 934-B-E /1x0,3 complies with the standard EN 16852:2016 “Flame Arresters-Performance requirements, test methods and limits for use”.

The general suitability as a deflagration flame arrester when used with inflammable gas/air mixture and vapour/air mixture of inflammable liquids of the explosion group IIC (gap < 0,5 mm) had been verified by tests executed at the Institute for Safety Technology IBExU Freiberg. The results of it were confirmed by the issued EC prototype test certificate **IBExU14ATEX2080 X**.

On principle, for all cases of use the placement conditions, especially the following limits for the operating pressure and temperature have to be considered:

- maximum permissible operating pressure : 1,1 bar (absolute)
- maximum permissible operating temperature : 60°C

On delivery of the devices the technical parameter of the flame arrester with stating the EC prototype test certificate number are documented in the works test certificate according to EN 10204. In the declaration of compliance it is referred to the accordance with the harmonized standard EN 16852. The maintenance of the basic safety requirements according to directive 2014/34/EU has been confirmed.

2. Construction

The flame arrester 934-B-E/1x0,3 consists of housing (1), in which a metal foil element (3) above covering flange (2), set screws (4) and hexagon nuts (5) is clamped.

The metal foil element is winded with a gap width of 0,3mm.

For protection against effects of the weather and contamination the flame arrester is equipped with a metal sheet cover (6) and a safety guard (7), that are affixed by set screws (8) and distance sleeves (9) .

3. Marking

The information for marking the flame arrester are arranged on the nameplate (page 4/4).

The following data are indicated:

- Name and address of the manufacturer
- Type (including version number)
- Serial number and year of production
- Number of the certificate (EC prototype certificate-no.)
- EN number
- The specific mark for prevention of explosions in connection with the mark indicating the group of devices II, and the letter “G” (for areas where explosive gas, vapour, air mixtures are available)
- Explosion group
- The CE mark with the number of the indicated inspection authority, which act during production

Created By:	RMG	Date: 01.01.14	BS&B FlameSAF Limited, Limerick, Ireland
Approved By:	D. Hennessy	Date: 01.01.14	



Flame Arrester
934-B-E 125/1x0,3 to 934-B-E 300/1x0,3
Instructions for Operation and Maintenance

REV 1.0

Page 2/4

The metal foil is marked at the outermost wound element, as follows:

- name of the manufacturer
- gap width
- material number
- direction of winding

example: BS&B – 0,3 – 1.4571 – L

4. Installation

The arrangement and the installation of the flame arrester into the plant shall be done under observance of the rules applicable to the relevant range of use. Especially the instructions for accident prevention have to be observed.

A vertical installation position of the flame arrester has to be kept under any circumstances.

In the flange version the flame arrester is equipped with a flange adapter DN150 to DN300 PN10– form C or ANSI 150 RF. While flanging be careful that the sealing face is not damaged and that there is no foreign matter or grease between the flanges for no gap to the atmosphere can occur.

Please note: The sheet metal cover is only used for protection of the flame arrester element.

For transport or installation the flame arrester element is to attach after remove of the metal sheet cover at the ring nuts (13).

5. Maintenance

The maintenance includes a periodic visual control of the flame arrester, especially the flame arrester element with regard to contamination and appearance. The intervals for the maintenance works depend on the operating conditions and the kind how the individual media tend to contamination.

For change the metal foil element shall be dismantled:

The metal sheet cover (6) had to dismantled by loosening the acorn nuts (10). Then the distance sleeves (9), the flat washers (11) and the safety guard (7) are to remove.. After loosening of the hexagon nuts (5) and the hexagon screw (12) the housing flange (2) can be removed. The metal foil element (3) is careful take out of the housing. Please attend, that no mechanical damage at the metal foil can occur.

In case of minor contamination the flame arrester element shall be blown up with compressed air or hot vapour.

In case of major contamination a flushing with a cleaning agent can be carried out. After cleansing all parts which had been wetted by a cleansing agent shall be blown dry.

During the cleansing works no mechanical modifications may be done on the flame arrester element or on the housing parts of the flame arrester.

On principle, the flame arrester element has to be replaced by a new one, if:

- a fire occurred at the flame arrester element;
- loosening or distortions in the structure of the metal foil elements can be recognized;
- corrosion damages at the metal foil elements have been detected;
- in case of strongly contaminated metal foil elements, even after cleaning, a residual contamination of more than 30 % of the free flow cross-section remained.

Created By:	RMG	Date: 01.01.14	BS&B FlameSAF Limited, Limerick, Ireland
Approved By:	D. Hennessy	Date: 01.01.14	



Flame Arrester
934-B-E 125/1x0,3 to 934-B-E 300/1x0,3
Instructions for Operation and Maintenance

REV 1.0

Page 3/4

All works in connection with the replacement of metal foil elements in a flame arrester element shall be executed only by trained and authorized skilled personnel.

It is recommended to hold a spare metal foil element ready for each flame arrester.

In case of replacement of structural units only original spare parts listed in the spare parts list may be installed to ensure the required safety.

6. Spare part list

Table : Spare parts 934-B-E 150(125)/1x0,3 und 934-B-E 6“(5”)/1x0,3

Item No.	Designation	No.	Material	Order-No..
3	Metal foil element 1x0,3	1	NSt	FET994784000
6	Metal sheet cover	1	NSt	FET992728000
7	Safety guard	1	NSt	FET542001800

Table : Spare parts 934-B-E 200/1x0,3 und 934-B-E 8”/1x0,3

Item No.	Designation	No.	Material	Order-No.
3	Metal foil element 1x0,3	1	NSt	FET992609000
6	Metal sheet cover	1	NSt	FET994746000
7	Safety guard	1	NSt	FET532097100

Tabelle : Ersatzteile 934-B-E 250(300)/1x0,3 und 934-B-E 10“(12”)/1x0,3

Pos. Nr.	Benennung	Anz.	Werkstoff	Bestell-Nr.
3	Metal foil element 1x0,3	1	NSt	FET995541000
6	Metal sheet cover	1	NSt	FET992653000
7	Safety guard	1	NSt	FET532098800

Material marks

NSt ... stainless steel	K ... plastic (acryl glass)	
-------------------------	-----------------------------	--

Created By:	RMG	Date: 01.01.14	BS&B FlameSAF Limited, Limerick, Ireland
Approved By:	D. Hennessy	Date: 01.01.14	



Flame Arrester
934-B-E 125/1x0,3 to 934-B-E 300/1x0,3
Instructions for Operation and Maintenance

REV 1.0

Page 4/4

Assembly Drawing 934-B-E/1x0,3

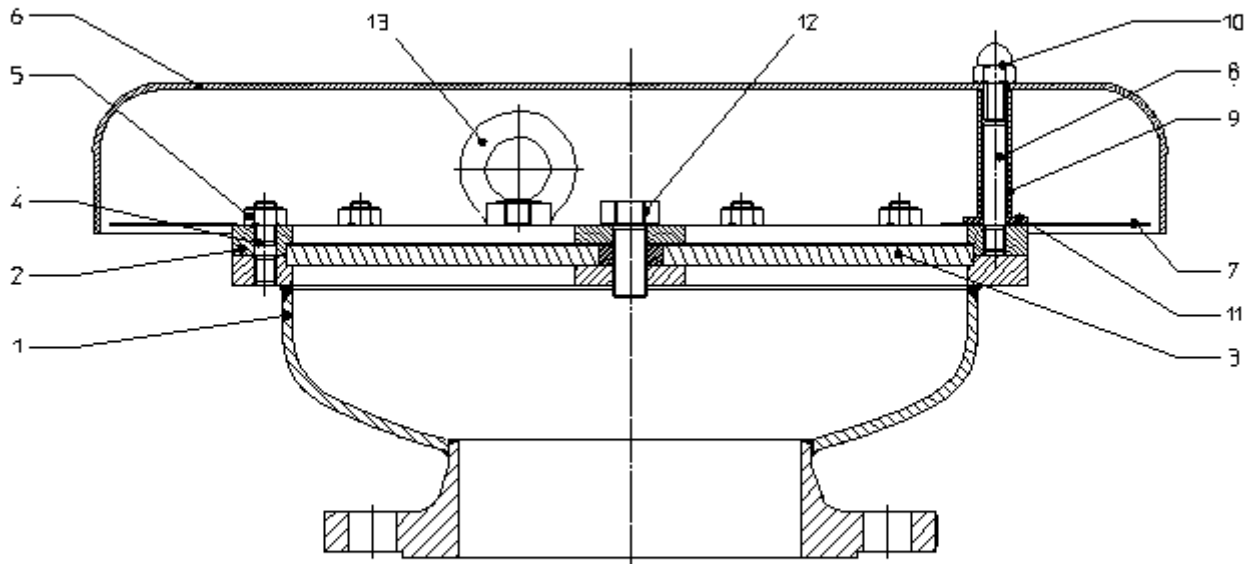

Created By:	RMG	Date:	01.01.14	BS&B FlameSAF Limited, Limerick, Ireland
Approved By:	D. Hennessy	Date:	01.01.14	