	<b>Vacuum vent 943-50 to 200</b>	REV 1.1
	<b>Instructions for operating and maintenance</b>	Page 1/4

For the vacuum vent type 943-DN catalogue data sheets as “Dimension sheet”, “Technical data” and “Pressure drop/volume flow charts” are available including the technical data, constructions and dimensions.

## 1. Use

Vacuum valve 943-DN complies with standard

DIN EN 13463 Non-electrical equipment for potentially explosive atmospheres  
 - Part 1: Basics methods and requirements: 2009-07  
 - Part 5: Protection by constructional safety "c": 2011-10

The general suitability as vacuum vent for device group II, category 1/2 when used with inflammable gas/air mixtures and vapour/air mixtures of inflammable liquids of explosion group IIB (standard gap width  $\geq 0.5$  mm) had been verified by tests executed at the Institute for Safety Technology IBExU GmbH Freiberg and the results were confirmed by the issued EC prototype test certificate **IBExU14ATEX1121 X**.

The following valve insert settings have to be considered :

- Set-pressure for vacuum: 2,5 up to 50 mbar \*) \*) factory pre-set default
- Operating temperature: -20 up to 160°C  
surface temperature  $\leq 80\%$  of ignition temperature medium  
(please attend data sheet)

On delivery of the devices the technical parameter of the valve with stating the EC prototype test certificate number are documented in the works test certificate according to EN 10204. In the declaration of compliance it is referred to the accordance with the harmonized standard EN 13463-1/-5. The maintenance of the basic safety requirements according to directive 2014/34/EU has been confirmed.

## 2. Construction

The vent consists of a cast iron housing (1), equipped with a vacuum valve insert (11). The housing is closed with a cover (3) by using of screws (6) and sealed by an O-ring (7). The valve insert is guided by a guiding socket screwed (4) into the cover. For protection against mechanical defects the vent is equipped with a protective strainer (2). It is clamped by screws (22) and plates (25).

The valve insert is pre-set for the customer's specific set-up vacuum via weight discs. It can be equipped with FEP sealing foil or with a metallic sealing surface.

## 3. Marking

The information for marking the vent are arranged on the nameplate (page 4/4).

The following data are indicated:

- Name and address of the manufacturer
- Type (including version number)
- Serial number and year of production
- Number of the certificate (EC prototype certificate-no.)
- The specific mark for prevention of explosions in connection with the mark indicating the group of devices II, category 1/2 and the letter “G” (for areas where explosive gas, vapour, air mixtures are available)
- Explosion group
- The CE mark with the number of the indicated inspection authority, which act during production
- Set-up pressure for vacuum valve
- Opening pressure for vacuum valve
- Volume flow at opening pressure

<b>Created By:</b>	<b>RMG</b>	<b>Date: 01.01.14</b>	<b>BS&amp;B FlameSAF Limited, Limerick, Ireland</b>
<b>Approved By:</b>	<b>D. Hennessy</b>	<b>Date: 01.01.14</b>	

	<b>Vacuum vent 943-50 to 200</b>	REV 1.1
	<b>Instructions for operating and maintenance</b>	Page 2/4

#### 4. Installation

The arrangement and the installation of the vent into the plant shall be done under observance of the rules applicable to the relevant range of use. Especially the instructions for accident prevention have to be observed. A vertical installation position of the vent has to be kept under any circumstances. A minimum distance of vent outlet to external devices has to be adhered to avoid reduction of volume flow. This minimum distance depends on local circumstances and has to be specified by operator.

The vent is equipped with a flange connection PN10 Form C or ANSI 150 RF. For the flanged joints flat gaskets with a sealing parameter  $k_{oD} \leq 25b_D$  are recommended. While flanging be careful that the sealing strips are not damaged and there is no foreign matter or dirt between the flanges, so that no gap to the atmosphere can occur.

The valve has to be included in the equipotential bonding of the vessel or plant.

**To prevent transportation damage, the valve inserts are blocked with a transportation safeguard, which must be removed as follows:**

- Uninstall cover (3) by loosening the screws (6)
- Remove transportation safeguard (corrugated card board) of the valve insert (11)
- Check the valve insert for easy mobility and proper location on the guiding socket (4)
- Place the valve insert upon the valve seat (10)
- Install the cover (3) and pull screws (6) tight
- When placing the cover, make sure that the guiding socket (4) in the cover is guided properly across the guiding bolt of the valve insert.

**Always regard „Transportation guard page“!**

#### 5. Maintenance

The maintenance includes a periodic visual control of the vent with regard to contamination and appearance. The intervals for the maintenance works depend on the operating conditions and the kind how the individual media tend to contamination. The interval of maintenance has to be defined by the operating company.

For cleaning purposes, the vent must be opened as follows:

Remove the screws and plates (22, 25) to uninstall the strainer (2). In case of major contamination a flushing with a cleaning agent can be carried out. All parts shall be blown dry after cleaning. During the cleaning works, no mechanical modifications may be done on all elements or the housing, else they has to be replaced by a new one.

All works in connection with repair and replacement of components shall be executed only by trained and authorized skilled personnel.

Valve seat and valve plate shall be checked for contamination and damages and examined in particular for intactness as well. Damages to the valve seat shall be eliminated by expert grinding and smoothing. Depending on the sealing system, the FEP seal or metallic sealing surface should indicate not damaging, else they has to be replaced by a new one.

Opening and re-installing shall be performed as described under 4.

It is recommended to hold a spare parts respective seals ready for each vent. In case of replacement of structural units only original spare parts listed in the spare parts list shall be installed to ensure the required safety.

<b>Created By:</b>	<b>RMG</b>	<b>Date: 01.01.14</b>	<b>BS&amp;B FlameSAF Limited, Limerick, Ireland</b>
<b>Approved By:</b>	<b>D. Hennessy</b>	<b>Date: 01.01.14</b>	



**Vacuum vent  
943-50 to 200  
Instructions for operating and maintenance**

REV 1.1

Page 3/4

**6. Spare part list**

Item No.	Description	Qty.	Material	Order No.		
				DN50	DN80	DN100
2	protective strainer	1	NSt	052099200	052099300	052099400
3	cover – complete	1	St NSt	FET15415132 FET15415133	FET15416066 FET15416067	FET15416586 FET15416587
6	cylinder head screw	4 6	NSt	242035000	242035000	242032100
11*	valve insert – FEP - valvedisk - FEP-seal surface	1	NS/FEP	FET15415115 812071200 722087800	FET15416080 812071900 722088300	FET15416572 812071500 722088100
	valve insert – metal - valvedisk - metal-seal surface	1	NSt	FET15415116 812071200 FET992784000	FET15416095 812071900 FET992876000	FET15416573 812071500 FET999657900
7	o-ring	1	NBR FPM EPDM FPM/FEP	812072800 802087800 812072900 812073000	802039700 802039800 802039900 802040000	812073100 812073400 812073200 812073300
22	cylinder head screw	3 4	NSt	232015400	232015400	232015500
25	plate	3 4	NSt	302028800	302028800	302028800

Item No.	Description	Qty.	Material	Order No.	
				DN150	DN200
2	protective strainer	1	NSt	052099500	052099600
3	cover – complete	1	St NSt	FET15417183 FET15417184	FET15417544 FET15417545
6	cylinder head screw	8	NSt	222075300	232098200
11*	valve insert – FEP - valvedisk - FEP-seal surface	1	NS/FEP	FET15417172 812072100 722088700	FET15417570 812072300 722088900
	valve insert – metal - valvedisk - metal-seal surface	1	NSt	FET15417173 812072100 FET999671400	FET15417572 812072300 FET993108100
7	o-ring	1	NBR FPM EPDM FPM/FEP	802078200 802078300 802078400 802078500	802078600 802078700 802078800 802078900
22	cylinder head screw	4 8	NSt	232015400	232015400
25	plate	4 8	NSt	302028800	302028800

\* Valve inserts without added weights

**Material marks**

St ... steel	LM ... light metal	FPM ... Viton	FEP .. Fluoride plastic
NSt ... stainless steel	K ... plastic	NBR ... Perbunan(N)	PTFE .. Fluoride plastic

<b>Created By:</b>	<b>RMG</b>	<b>Date: 01.01.14</b>	<b>BS&amp;B FlameSAF Limited, Limerick, Ireland</b>
<b>Approved By:</b>	<b>D. Hennessy</b>	<b>Date: 01.01.14</b>	



Vacuum vent  
943-50 to 200  
Instructions for operating and maintenance

REV 1.1

Page 4/4

Assembly drawing

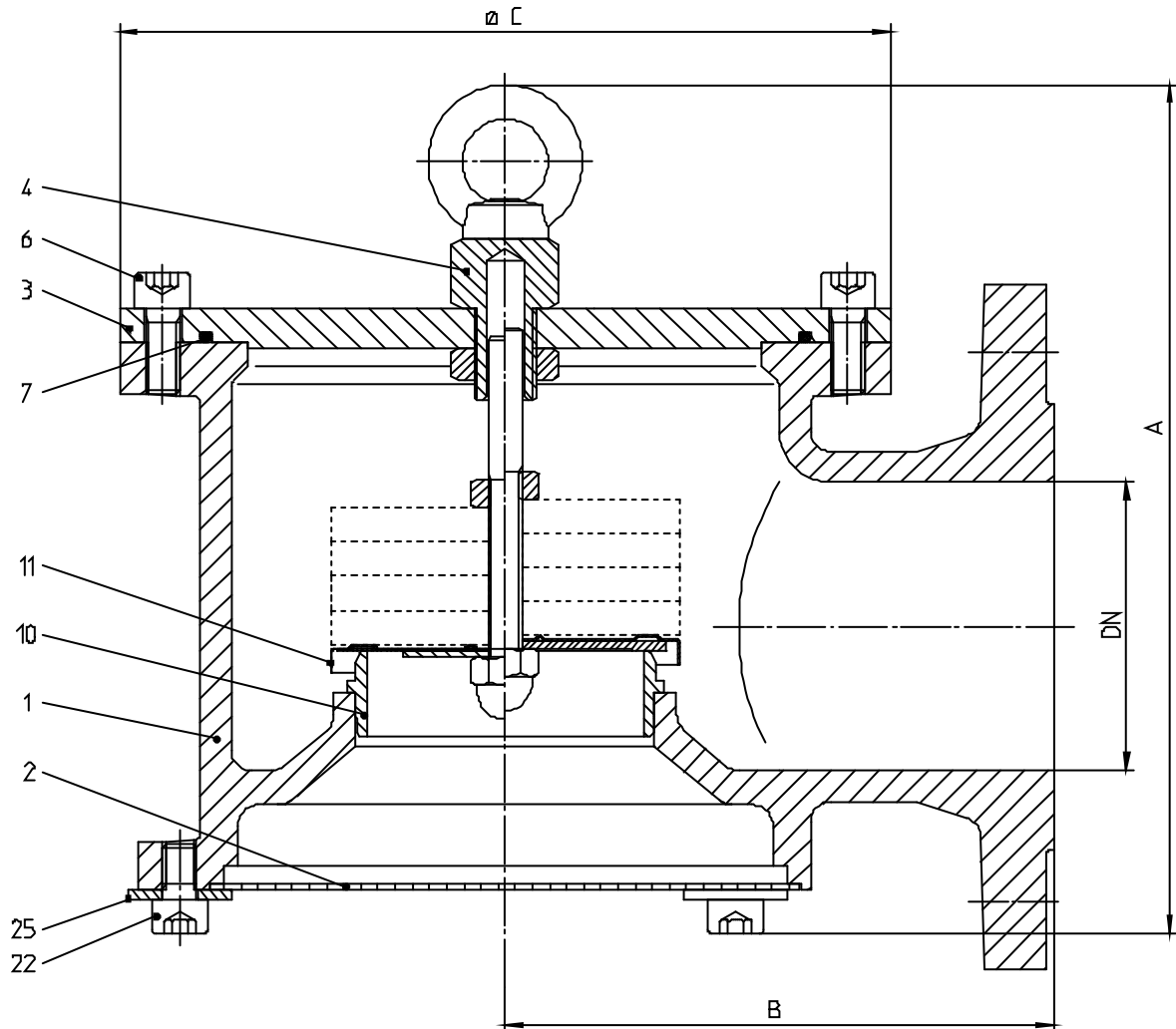

DN	A [mm]	B [mm]	ø C [mm]
50 / 2"	185	125	170
80 / 3"	250	160	225
100 / 4"	270	163	225
150 / 6"	310	210	320
200 / 8"	363	248	375

Created By:	RMG	Date: 01.01.14	BS&B FlameSAF Limited, Limerick, Ireland
Approved By:	D. Hennessy	Date: 01.01.14	