



BS&B SAFETY SYSTEMS, L.L.C.
BS&B SAFETY SYSTEMS LTD.

SAF-T-GRAF® REPLACEABLE ELEMENT

CATALOG
77-8550

SECTION C

GRAPHITE DISKS



SAF-T-GRAF® FEATURES

- Fail-safe — the same burst pressure in either direction (Model RE).
- Offers superior sealing characteristics to process gases and fluids.
- Burst pressures of armored disks are unaffected by excessive or uneven torquing of the flange studs.
- Higher operating temperatures than other graphite disks (up to 205°C/400°F).
- Operating temperatures to 427°C (800°F) available with a high temperature assembly.
- Offers cost advantages over other designs of graphite disks as the safety head can be re-used.
- Corrosion resistant to most process chemicals.
- Burst pressures from 0.07 bar (1psig) to 30 bar (435 psig).
- Nominal sizes 25mm (1") to 600mm (24").
- Full bore opening.
- Extended service life for operating pressure up to 80% of the disk's rated burst pressure.
- Suitable for gas or liquid service.
- Supports full vacuum (a vacuum support is required below 1.52 bar (22 psig) burst pressure).
- Non-toxic and environmentally safe.
- Optional TFE liner attached to the disk for extra protection against corrosion and prevention of product build-up.(Model REL)
- Anti-stick TFE coating also available.
- Patent pending.

OPERATING RATIO

Up to 80% operating pressure to burst pressure ratio.

INSTALLATION

The disks are designed to be assembled into separate safety heads before insertion between standard pipe flanges.

FLANGE RATINGS

The safety heads are designed to fit between all standard international pipe flanges (ANSI, DIN, AFNOR, JIS, BS) and to nestle within the flange bolts.

GASKETS

Optional safety head gaskets are available – consult BS&B.

HIGH TEMPERATURE ASSEMBLY

A High Temperature Assembly is required for service temperatures exceeding 205°C (400°F). The H.T.A., consisting of an efficient thermal insulator, is located on the process side of the safety head. Temperatures up to 427°C (800°F) can be accommodated.

ARMOR

An armoring ring is recommended for all graphite disks for added safety eliminating premature bursting of the disk due to uneven or excessive torquing of the pipe flange studs. Armoring minimizes the probability of damage in transit and during installation.

Carbon steel is standard with stainless steel offered as an option.

MODEL RE

The unique fail safe design of the RE type disk assures the disk cannot be installed incorrectly in the safety head as the disk will burst at its rated burst pressure in either direction. Additionally the disk and safety head assembly may be installed in either direction between pipe flanges. A disk with a burst pressure of 1.52 bar (22 psig) or above will withstand full vacuum.

RE-7R SAFETY HEAD

The RE type disk is installed in a precision machined RE-7R safety head for direct installation between standard international pipe flanges.



Type RE graphite disk in RE-7R graphite safety head.

MODEL REL

An REL type disk with a TFE liner permanently attached to the process side of the disk can be supplied for extra protection against corrosive fluids or to prevent product build-up.

FLANGE RATINGS

The safety heads are designed to fit between all standard international pipe flanges, ANSI, DIN, AFNOR, BS, JIS and to nestle within the flange bolts.

MATERIAL

Safety heads are available in impregnated graphite or 316SS as standard.



Type REL graphite disk in REL-7R 316SS safety head.



Type REV graphite disk in REV-7R graphite safety head.

MODEL REV

The REV type disk is suitable for applications where vacuum conditions exist and when the burst pressure is less than 1.52 bar (22 psig).

REV-7R SAFETY HEAD

A REV disk inserted in a REV-7R safety head is used in applications where vacuum conditions exist and when the rated bursting disk pressure is less than 1.52 bar (22 psig). A locating pin on the disk mates with a location hole in the safety head thus eliminating incorrect installation. The REV-7R safety head is provided with an integral non-opening vacuum support on the process side of the safety head. The free flow areas for the dial type vacuum support are shown in table 1.

Vacuum supports are designed utilizing the latest computer software to maximize venting capacities while maintaining structural strength.

Flow arrows on the side of the safety head facilitate correct installation between pipe flanges.

Safety heads are machined to meet ANSI B16.5 standards concerning serrations and finish.

FLANGE RATINGS

The safety heads are designed to fit between all standard international pipe flanges, ANSI, DIN, AFNOR, BS, JIS and to nestle within the flange bolts.

MATERIAL

Safety heads are available in impregnated graphite or 316SS as standard.



Type REV graphite disk in REV-7R 316SS safety head.

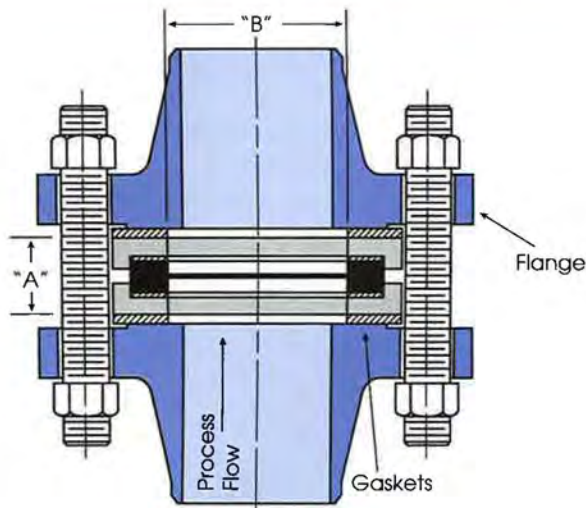

RE/RE-7R

Type RE graphite bursting disk in RE-7R Safety Head.

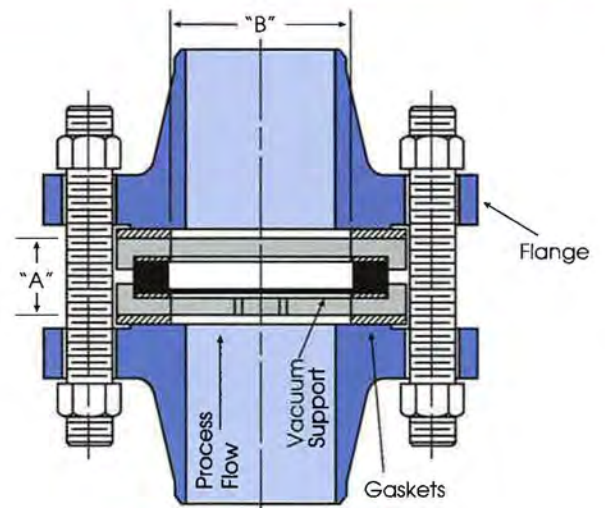

REV/REV-7R

Type REV graphite bursting disk in REV-7R Safety Head.
(Type REL/REL-7R excluding vacuum support.)

TABLE 1
RE, REL & REV Type Specifications

Nominal (In.)	Size (mm)	Burst Ratings @ 22°C (72°F)				Internal Diameter "B"		Total Assembly Thickness "A"				Free Flow Area% with vacuum support
		min.		max.				316SS		Graphite		
		barg	psig	barg	psig	(mm)	(In.)	(mm)	(In.)	(mm)	(In.)	
1	25	0.70	10.0	30.0	435	32	1.26	28	1.10	28	1.10	91
1.5	40	0.48	7.0	20.0	290	48	1.89	28	1.10	31	1.22	91
2	50	0.20	3.0	15.0	217	64	2.52	28	1.10	32	1.26	100
2.5	65	0.20	3.0	12.0	174	76	2.99	30	1.18	37	1.46	94
3	80	0.15	2.2	10.0	145	89	3.50	35	1.38	42	1.65	82
4	100	0.15	2.2	8.0	116	114	4.49	37	1.46	47	1.85	85
5	125	0.10	1.5	6.0	87	140	5.51	40	1.57	47	1.85	79
6	150	0.07	1.0	5.0	72	165	6.50	44	1.73	47	1.85	77
8	200	0.07	1.0	4.0	58	216	8.50	50	1.97	61	2.38	74
10	250	0.07	1.0	3.0	43	267	10.51	53	2.09	68	2.68	74
12	300	0.07	1.0	2.5	36	318	12.52	61	2.40	76	2.99	71
14	350	0.07	1.0	2.0	29	356	14.02	63	2.48	80	3.15	67
16	400	0.07	1.0	1.5	21	406	15.98	70	2.76	83	3.27	64
18	450	0.07	1.0	1.5	21	457	17.99	77	3.03	92	3.62	64
20	500	0.07	1.0	1.2	17	508	20.00	88	3.46	105	4.13	62
24	600	0.07	1.0	1.2	17	610	24.02	93	3.66	111	4.37	61

REL type disks are offered with higher minimum burst pressures.

ORDERING INFORMATION

DISK STYLES

MODEL

- Replaceable disk
for low to medium pressuresRE
- Replaceable disk
with TFE liner on process side of diskREL
- Replaceable disk
for vacuum service conditions with burst
pressures below 1.52 bar (22 psig)REV

Order replacement disks by lot number (or part number) indicated on disk tag.

SAFETY HEAD STYLES

MODEL

- Insert Type for RE diskRE-7R
- Insert Type for REL diskREL-7R
- Insert Type with integral vacuum
support for REV and REL disks
in vacuum service conditions and
with disk burst pressure below
1.52 bar (22psig)REV-7R

SIZES

25mm (1") to 600mm (24"), larger sizes available on request.

BURST PRESSURES

0.07 bar (1 psig) to 30 bar (435 psig). Burst pressures vary depending on size of disk. Consult table 1, RE and REV specification chart.

VACUUM SUPPORT – TYPE REV

Vacuum supports are the non-opening type and are incorporated into the safety head. The standard design of the vacuum support is the dial type. The safety head with integral vacuum support is required for burst pressures below 1.52 bar (22 psig) and where a vacuum condition exists.

CORROSION RESISTANCE

Impregnated graphite is resistant to most corrosive media. A bursting disk can be supplied with a TFE liner attached to the process side of the disk for extra protection against corrosion and prevention of product build-up. Specify Model REL.

FLANGE RATING

The safety head can be supplied to fit flange ratings ANSI, DIN, AFNOR, BS, and JIS. Please advise flange specification when ordering.

OPERATING RATIO

Up to 80% operating pressure to burst pressure ratio.

ARMOR

An armoring ring is recommended for all graphite disks for added safety eliminating premature bursting of the disk due to uneven or excessive torquing of the pipe flange studs. Armoring minimizes the probability of damage in transit and during installation.

Carbon steel armor is standard with stainless steel offered as an option.

Armoring is standard in the following sizes and with burst pressures in excess of the following:

Size	Burst Pressure	
	psig	bar
1" (25mm)	130	8.9
1½" (40mm)	115	7.9
2" (50mm)	100	6.9
2½" (65mm)	93	6.4
3" (80mm)	85	5.9
4" (100mm)	70	4.8
5" (125mm)	60	4.1
6" (150mm)	50	3.4
8" (200mm)	40	2.8
10" (250mm)	30	2.1
12" (300mm)	25	1.7
& above		

TEMPERATURE

SAF-T-GRAF graphite bursting disks are suitable for use at temperatures from -73°C (-100°F) to 205°C (400°F). Higher temperatures up to 427°C (800°F) are accommodated using a high temperature assembly.

If a disk is ordered with a burst temperature within 4.5°C (40°F) to 38°C (100°F) it will be burst tested and rated at 22°C (72°F).

If the requested temperature is outside this range (4.5°C (40°) to 38°C (100°F)) the burst tests will be carried out at ambient temperatures and a correction coefficient will be applied to estimate the burst pressure at the requested burst temperature.

Burst test certificates will show the burst pressure at 22°C (72°F) and the estimated burst pressure at the requested temperature.

BURST TOLERANCE

The burst tolerance is the maximum variation from the rated burst pressure.

<u>RATED BURST PRESSURE</u>	<u>TOLERANCE</u>
less than 0.07 bar (1 psig)	-0, +0.052 bar† (0.75 psig)
0.07 bar (1 psig) — 1.03 bar (15 psig)	+/- 0.052 bar (0.75 psig)
above 1.03 bar (15 psig)	+/- 5%

† For reduced tolerances consult BS&B.

Example:

If a Saf-T-Graf RE type disk is ordered with a 2 bar (29 psig) burst pressure, it will burst between 1.9 bar (27.5 psig) and 2.1 bar (30.5 psig).

NOTE: Products, specifications, and all data in this literature are subject to change without notice. Questions regarding product selection and specifications for specific applications should be directed to BS&B, Attn: Customer Service Dept.

ISO 9001 Quality System



**BS&B SAFETY SYSTEMS, L.L.C.
BS&B SAFETY SYSTEMS LTD.**

BS&B SAFETY SYSTEMS, LTD.

Bay G-1, Raheen Business Park, Limerick, Ireland

Tel: +353 61 227022. Fax: +353 61 227987

E-mail: sales@bsb.ie

www.bsb.ie

BS&B SAFETY SYSTEMS, L.L.C.

7455 East 46th Street, Tulsa, OK 74145, USA

Tel: 1-918-622-5950. Fax: 1-918-665-3904

Toll Free: 1-800-BSB-DISK

E-mail: mktg@tul.bsbsystems.com

www.bsbsystems.com

Visit our website

www.bsbsystems.com

